

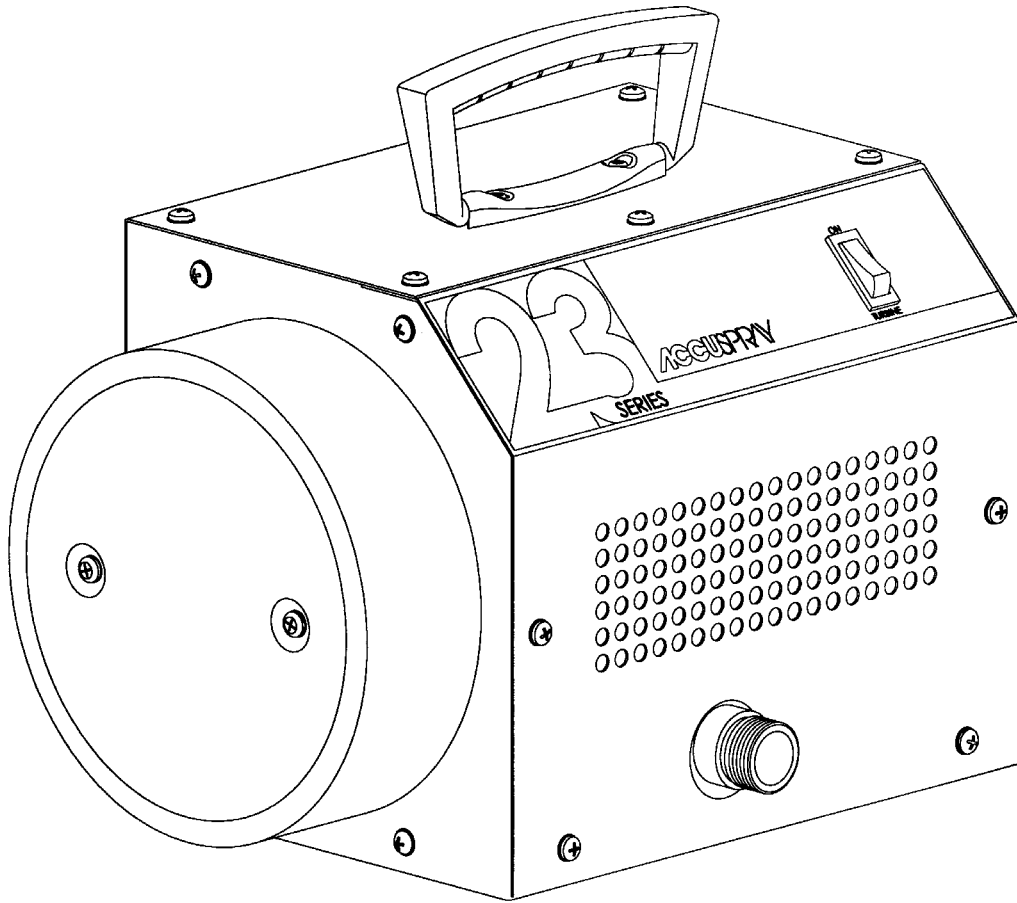

# 23 Series

## 3 Stage Portable Turbine Package Owners Manual



**This Manual Covers All 23 Series and 23-HV Series Models**

---

## Table of Contents

General Safety.....	2
Operating Guidelines.....	3
General Overview.....	4
Set Up Instructions.....	5
Hand Gun Use.....	6
Hand Gun Maintenance.....	8
Spray Gun Parts Identification.....	9
Turbine Maintenance.....	10
Turbine Parts Identification.....	11

### General Safety

Accuspray's HVLP equipment is for professional use only. Hazards can occur from equipment misuse. Any misuse of the equipment or accessories, such as over pressurizing, modifying parts, using incompatible chemicals and fluids, or using worn or damaged parts can cause serious bodily injury, fire, explosion or property damage. **Read, understand and follow all general safety, safety precautions and user instructions before using your Accuspray equipment.**

- **NEVER** try to stop or deflect fluid leaks with your hand or body.
- **NEVER** alter or modify any part of this equipment.
- **CHECK** your spray equipment before each use. Repair or replace worn or damaged parts immediately.
- **ALWAYS** use Accuspray replacement parts. Only these parts were designed to work with your equipment.

### Safety Precautions

Solvents and coatings can be highly flammable to combustible, especially when sprayed. Adequate exhaust must be provided to keep the air free of accumulations of flammable vapors. Smoking must never be allowed in spray areas. Fire extinguishing equipment must be present in the spray area.

Certain materials may be harmful if inhaled or if there is contact with the skin. Follow the requirements of the Material Safety Data Sheet supplied by the coating manufacturer. Use a respirator whenever there is a chance of inhaling sprayed material. The mask must be compatible with the material being sprayed and its concentration. Safety equipment must be NIOSH approved.

Certain solvents containing Methylene Chloride and Trichloromethane are not chemically compatible with aluminum or zinc. The solvents reaction can become violent or explosive. If you are in doubt whether a coating or cleaning material is compatible, contact your material supplier.

Improper operation or maintenance may create a hazard. Personnel must be given training. Instructions and safety precautions must be read and understood. Comply with your local, state, and national codes governing ventilation, fire protection, operation, maintenance, and housekeeping.

**\*\*Note:** Only operate unit in dry area. Locate unit as far from spray area as possible. Be sure to keep spray area well ventilated. Keep all ventilation openings on the unit free of obstructions. Do not handle plug or unit with wet hands.

# Operating Guidelines

## Introduction:

This product shall be grounded. In the event of an electrical short circuit, grounding reduces the risk of electrical shock by providing an escape wire for the electrical current. This product is equipped with a cord having a grounding wire with an appropriate grounding plug. The plug must be plugged into an outlet that is properly installed and grounded in accordance with all local codes and ordinances.

**Danger:** Improper installation of the grounding plug can result in a risk of electrical shock. If repair or replacement of the plug or cord is necessary, do not connect the grounding wire to either flat blade terminal.

Check with a qualified electrician or serviceman if the grounding instructions are not completely understood, or in doubt as to whether the product is properly grounded. Do not modify the plug provided; if it will not fit the outlet, have the proper outlet installed by a qualified electrician.

This product is for use with a nominal 120 volt circuit, and has a grounding plug that looks like the plug in Figure A.

## Extension Cords

Use only a 3-wire extension cord that has a 3 blade grounding plug, and a 3 slot receptacle that will accept the plug on the product. Make sure that your extension cord is in good condition. When using an extension cord, be sure to use one heavy enough to carry the current your product will draw. An undersized cord will cause a drop in line voltage resulting in a loss of power and overheating. Figure B contains a table showing the correct size to use depending on cord length and nameplate ampere rating. If in doubt, use a heavier gauge. Note that the smaller the gauge number, the heavier the cord.

## Cord Care

Do not operate unit with damaged cord or plug. Do not pull or carry by cord, or use the cord as a handle. Do not close door on cord, or pull cord around sharp edged corners. Keep cord away from heated surfaces. Do not unplug by pulling on cord. To unplug, grasp the plug, not the cord. When not in use, bundle the cord to avoid damage or accident.

## Product Storage

Do not leave unit plugged when not in use. When not in use, store unit in a dry area. Avoid storing in temperatures below freezing. If unit is left in freezing or below freezing temperatures, allow it to warm to room temperature before use.

Operating the unit while cold will cause damage. A unit stored in freezing or below freezing temperatures can take one hour or longer to reach room temperature.

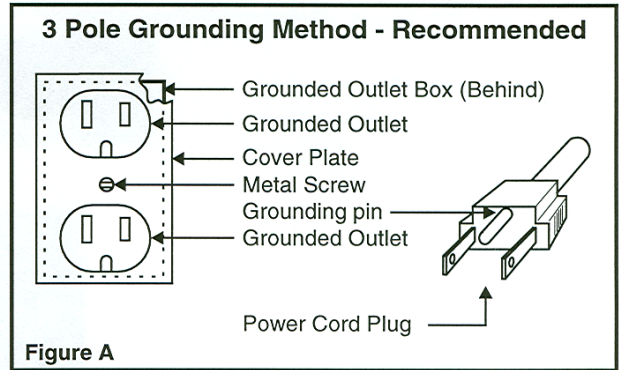

Ampere Rating Range (120 Volts)	Minimum Gauge for Extension Cords								
	Length of Cord in Feet								
	25 ft.	50 ft.	100 ft.	150 ft.	200 ft.	250 ft.	300 ft.	400 ft.	500 ft.
0-2	18	18	18	16	16	14	14	12	12
2-3	18	18	16	14	14	12	12	10	10
3-4	18	18	16	14	12	12	10	10	8
4-5	18	18	14	12	12	10	10	8	8
5-6	18	16	14	12	10	10	8	8	6
6-8	18	16	12	10	10	8	6	6	6
8-10	18	14	12	10	8	8	6	6	4
10-12	16	14	10	8	8	6	6	4	4
12-14	16	12	10	8	6	6	6	4	2
14-16	16	12	10	8	6	6	4	4	2
16-18	14	12	8	8	6	4	4	2	2
18-20	14	12	8	6	6	4	4	2	2

**Figure B**

## Before First Use:

The following tips can help to ensure proper operation, avoid damage to the system, prevent personal injury, and extend equipment life.

- \*Read and follow all safety instructions.
- \*Always use the proper, grounded extension cord of appropriate length and gauge. Failure to do so voids all warranties and will greatly shorten the life of the turbine motor.
- \*Always fully release all pressure before opening, cleaning, or servicing any part of this system.
- \*Always spray at the lowest possible pressure to correctly atomize your coating. Over-pressurizing wastes material, increases overspray and works the unit harder than necessary.

## General Overview

The combination of an Accuspray Turbine with an Accuspray HVLP Hand Gun delivers the performance needed for professional results. The 23K is a 3 stage portable turbine unit producing atomizing air. The unit delivers 85 cfm and 5psi to the gun. It weighs approximately 18 pounds.

Your turbine spray gun is set up to deliver the desired production speed and finish quality for frequently used architectural coatings. The gun components, including the corrosion-resistant fluid passage, are compatible with solvent-based or water-based materials. With proper use and maintenance your Accuspray system will deliver long trouble-free life and the highest quality results.

The 10 or 14 series is a non-bleed gun for use with turbine air systems or compressed air systems. Air stops flowing through the gun when the trigger is fully released. The 10 or 14 series can be used with compressed air with the use of a 0 to 10 psi regulator, Part #36-00.

The 11 or 15 series gun is a bleeder gun for use with turbine air systems only. This series is a free-flow design which allows air to flow through the gun even after the trigger is released.

---

### What You Should Have In the 23K Package

- ❑ 3-Stage Turbine Unit
- ❑ Turbine Gun
- ❑ 1 Quart Cup
- ❑ 30Ft Air Atomizing Hose

### Accessories

41-22	1 Quart Cup
92-303/2	Replacement Brushes (2)
91-028	10 Series Maintenance Kit
92-254	Turbine Filter Pack
94-049/3	Check Valves (3)
94-234	Storage Cap/Cup Assembly
94-233	Storage Cup Assembly
60-4116530	Turbine Air Hose Assembly

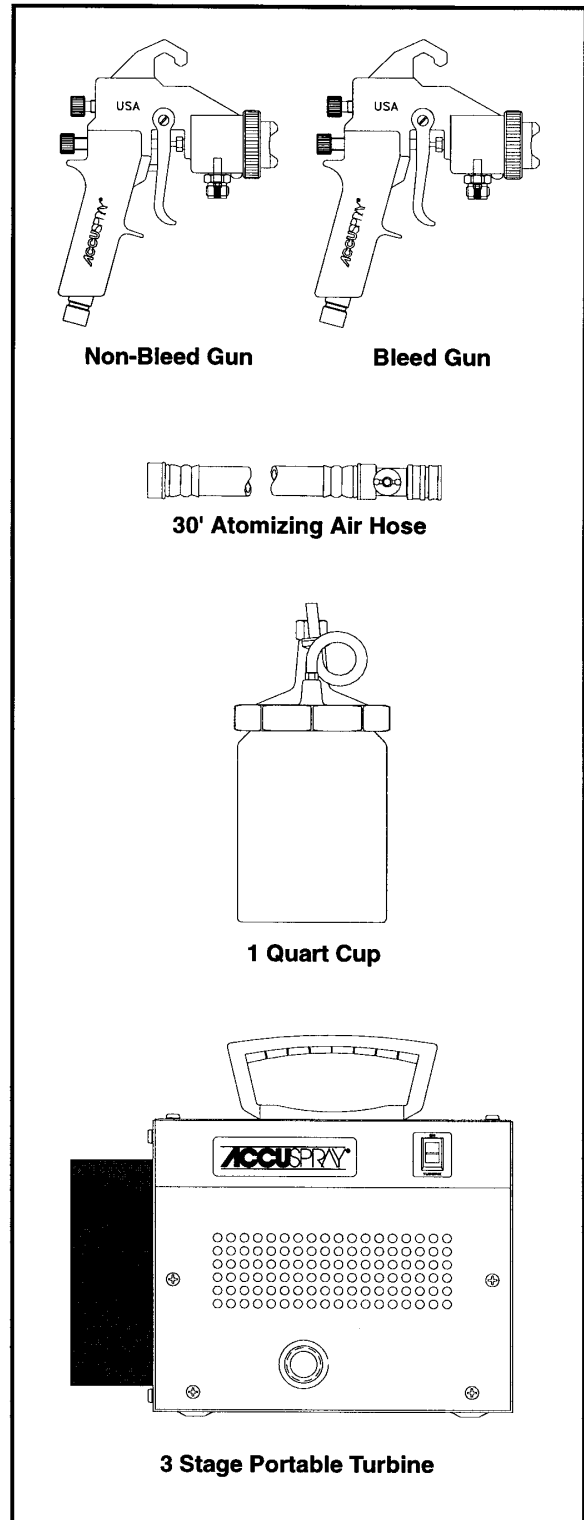

# Set-Up Instructions

## Gun/Cup Installation

Thread the swivel nut of the cup lid onto the fluid inlet fitting of the spray gun. Tighten with an Accuspray Gun Wrench while applying counterforce with an 11/16" wrench on the fluid inlet fitting of the spray gun.

Before fully tightening, make certain that the fluid tube is pointed forward. Attach the pressure tube from the pressure stem on the gun head to the cup lid.

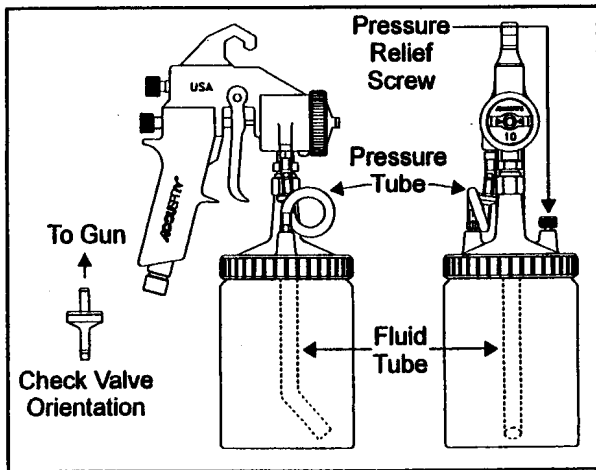

## External Check Valve Assembly

To install the assembly, attach the short pressure tube hose from the check valve assembly to the gun. Loop the tube and attach it to the pressure stem of the cup. The loop plays an important role; it allows you to see any material that may be working its way back up the tube.

A properly working check valve is required for uninterrupted spraying. The advantage of the external check valve is that in its remote location (away from the fluid reservoir) it is not prone to becoming clogged. The external check valve is a wear part and it will require replacement after it becomes contaminated. The normal life expectancy is from one week to three months, depending on its care.

## Turbine Unit Assembly and Connection

Attach the air hose to turbine outlet.

Connect the Q.D. end of the air hose to the gun. Mix the material to be applied to the recommendations of the supplier.

The electrical plug of the turbine connects to any standard 110 volt receptacle. The turbine delivers atomization air to the spray gun.

Check to see that the on/off switch is in the off position. Plug in the unit. With everything connected and with solution in the cup, and the pressure relief screw closed, the switch can be turned on.

## Check List – Before You Spray

- Locate turbine as far from the spray area as possible
- Be sure that the pressure relief vent at the rear of the turbine is free of obstructions
- Be sure that the cup pressure relief screw is closed
- Test fan pattern on scrap material first.
- Be sure the spray area is well ventilated.

# Hand Gun Use

## Gun Adjustments

The fan size is regulated by the fan adjustment located at the top, rear of the gun. As a starting point, gently turn the knob clockwise until you feel no further adjustment. Next, turn the knob counter-clockwise one full rotation. The fan adjustment will allow you to spray from a small round to a full wet pattern. The pattern can also be changed from vertical to horizontal by rotating the air cap ¼ turn.

The fluid flow can be adjusted by the needle adjustment screw. The needle adjustment screw is located directly below the fan adjustment knob. As a starting point, gently turn the knob clockwise until you have very little needle travel. (Pull trigger to verify). Do not over-tighten. After the needle travel has stopped, further tightening will only serve to compress the spring and will not aid in adjustment.

Next turn the knob counterclockwise two full turns. These adjustment procedures will serve only as a starting point. Fine tuning of these adjustments will be based on your material and technique.

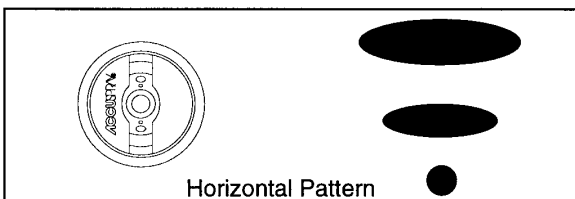
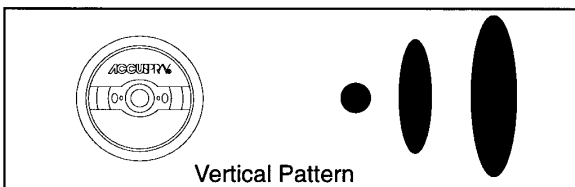
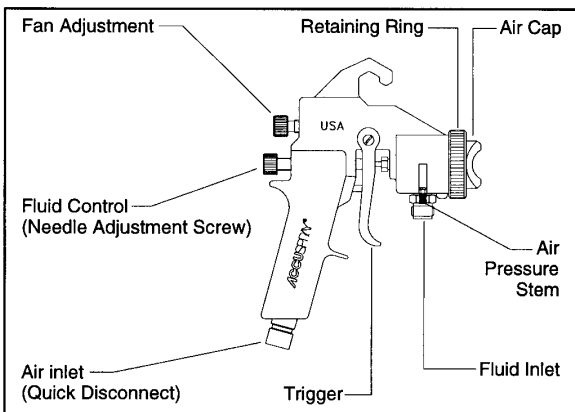

## Needle tips/nozzles and air caps.

The atomizing set in your gun was selected for its performance with various coatings. At the same time, different sizes of needle tips/nozzles or air caps can improve the results with coatings of different viscosities. To extend the versatility of your Accuspray gun, please see general guidelines for needle tips/nozzles and air caps.

### To Change Needle Tips and Nozzles:

- 1) Remove the retaining ring and air cap.
- 2) Squeeze the trigger and keep the needle retracted for the next procedure.
- 3) Remove the fluid nozzle from front of the gun with the gun wrench.
- 4) Release the gun trigger.
- 5) Unscrew the Delrin needle tip and replace.
- 6) Squeeze trigger again and hold.
- 7) Replace the fluid nozzle. Tighten the nozzle. Do not over-tighten.
- 8) Check the needle packing to ensure a proper seal.
- 9) Replace the air cap and retaining ring.

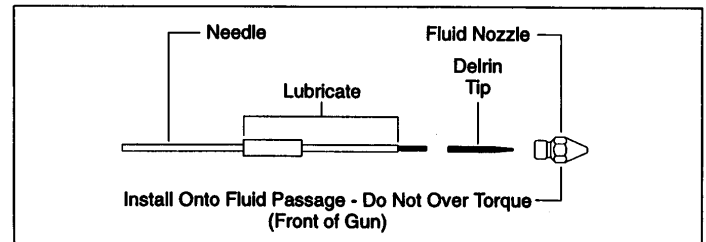

**Note: To prevent damage to the needle tip, be sure to follow steps 2 and 6 above when removing or replacing the fluid nozzle.**

# Hand Gun Use-Continued

## Spray Technique

Proper spray technique is very important to achieve professional results. Always spray at a distance of 6 to 8 inches from your target. Keep the gun parallel to your target throughout the entire pass. More detailed spraying can be done with the gun as close as 2 inches from the target. Make sure that your wrist remains firm during each pass.

Trigger the gun only after your pass begins, and release the trigger before stopping your motion. Do not angle your gun upward or downward while spraying. Angled spraying will develop an uneven buildup. Overlap your passes approximately 50% for an even application.

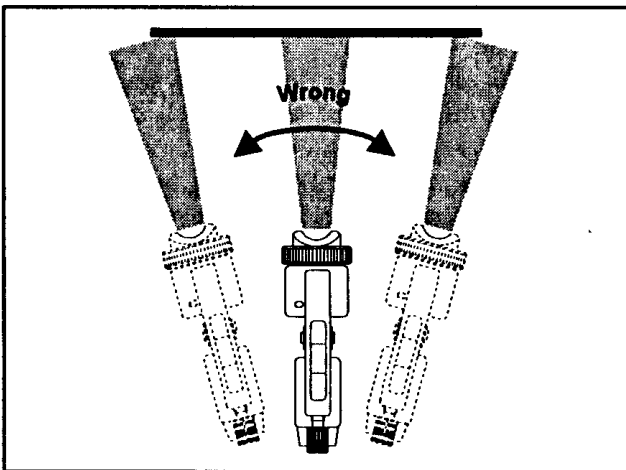
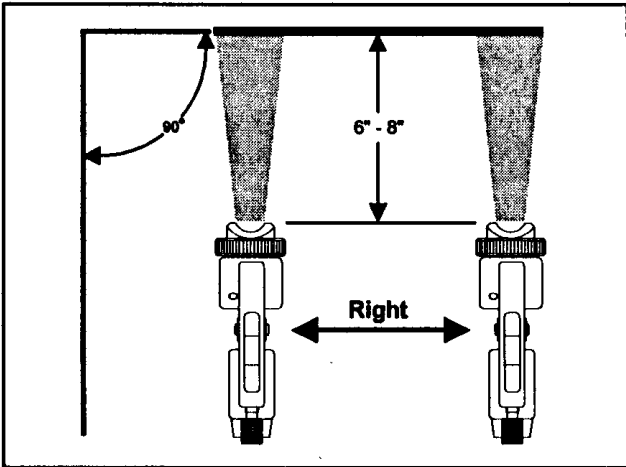

## Troubleshooting Chart-Finishing

<u>Problem</u>	<u>Cause</u>	<u>Remedy</u>
Bad Spay Pattern	Air Cap Clogged Nozzle Clogged Bent Fluid Needle	Use Cleaning Solution Replace Needle
Heavy Middle Pattern	Too much fluid pressure Not enough atomizing pressure	Reduce fluid Pressure Increase Atomizing Pressure
Pulsating Spray	Worn/Loose Packing Low Fluid in Cup	Tighten or Replace Add Fluid
Insufficient Fluid Flow	Fluid Nozzle Too Small	Use Larger Needle/Nozzle
Mottled Looking Surface	Coats Too Wet Improper Spray Technique	Reduce Fluid Flow Hold Gun Parallel to Work
No Fluid Flow	Clogged Fluid Nozzle Loss of Air Pressure Loss of Fluid Pressure Clogged Air Passage Restriction In Cup Clogged Check Valve	Clean Nozzle Check Air Hose Out of Material Clear Passage Flush Cup Replace Valve
Excessive Overspray	Gun too far from Target Too much Atomizing Air	6-8 Inches Ideal Reduce Air
Fluid Leak	Wrong Needle Size Damaged/Worn Needle Loose Fluid Nozzle Worn/Loose Packing Nut Tilted Gun Needle Not Closing	Replace Replace Tighten/Replace Tighten/Replace Do Not Tilt While Spraying Packing Too Tight Missing Needle Spring Dried Material On Needle

### Warning-Hose Safety:

Handle and route hoses carefully. Do not pull on hoses to move equipment.

# Hand Gun Maintenance

## Gun Cleaning

It is very important to clean your gun after every use. Do not clean the gun body with products containing formic acid or acetic acid. Please refer to the coating manufacturers MSDS for the proper cleaning agents to be used.

Accuspray does not recommend using a gun washer. After cleaning, blow out the gun with air and wipe off the exterior with the appropriate cleaning agents. You can place a small amount of cleaning agent in the cup, pressurize the cup, close your fan air down slightly, and trigger the gun until the stream runs clear.

## Lubrication

After every cleaning of the gun, you should lubricate the working components. Cleaning washes away the lubricants that protect these friction points. Lubricate with Accuspray gun lube part #91-170. The lubrication points are shown below.

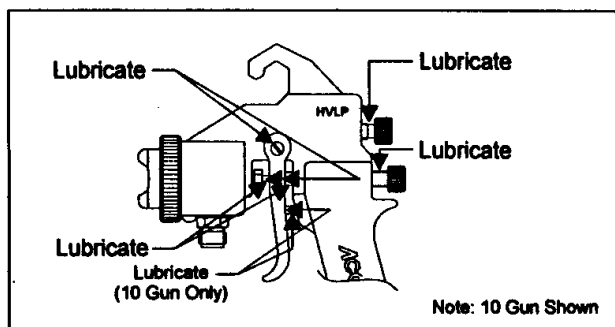

## Fluid Nozzle

If the fluid nozzle becomes clogged, spraying cleaning agent through the gun should clear the passage.

If it is necessary to remove and replace the fluid nozzle, care should be taken not to over tighten during replacement. The nozzle seals easily with the fluid passage, and no more than a 1/8 turn past finger tight is required to prevent fluid leaks.

**Note: Over tightening the stainless steel nozzle may damage the fluid passage.**

## Cup Cleaning

It is also very important to clean your cup after every use. Before removing your cup lid from the cup, be sure to relieve the cup pressure through the relief valve. Unscrew the cup lid and remove the remaining material from the cup. Rinse the cup with a suitable cleaning agent.

### Cup Warnings

1/2 Pint and 1 Quart Pressure Cup  
Do Not Exceed 10 psi  
Disconnect Atomizing Air Before Opening Cup  
Open Pressure Relief Screw Before Opening Cup

## Gasket Replacement

Remember that the cup is a pressure cup. The gasket must be in good condition. The lid must be firmly seated to the cup to prevent air and fluid leakage. Inspect the gasket, lube the gasket channel, and pay attention to the fit with each use. Replace the gasket when necessary.

## Packing and Packing Nut

To replace the fluid packing, first be sure to relieve all system pressure, and, if at all possible, clean the gun by flushing before proceeding.

Unscrew and remove the needle adjustment screw and the needle adjustment spring. Pull the needle out of the gun with your fingers. If the needle does not pull out freely, loosen the packing nut. Remove the packing nut with your gun wrench. The compression spring, needle guide, and seal should fall freely from gun. If you experience difficulty with removal, remove trigger pin and firmly tap the rear of the gun on a block of wood. Then remove the seal with an o-ring pick or similar narrow instrument.

To ease in removal of the packing nut, unscrew and remove the trigger pivot post and screw. Remove the trigger. Unscrew and remove the packing nut. Before inserting a new packing, be sure to lubricate it first with gun lube part #91-170.

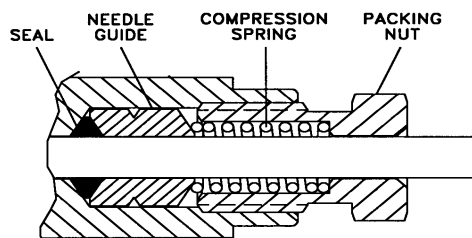

# 10-Series Hand Gun Parts Identification

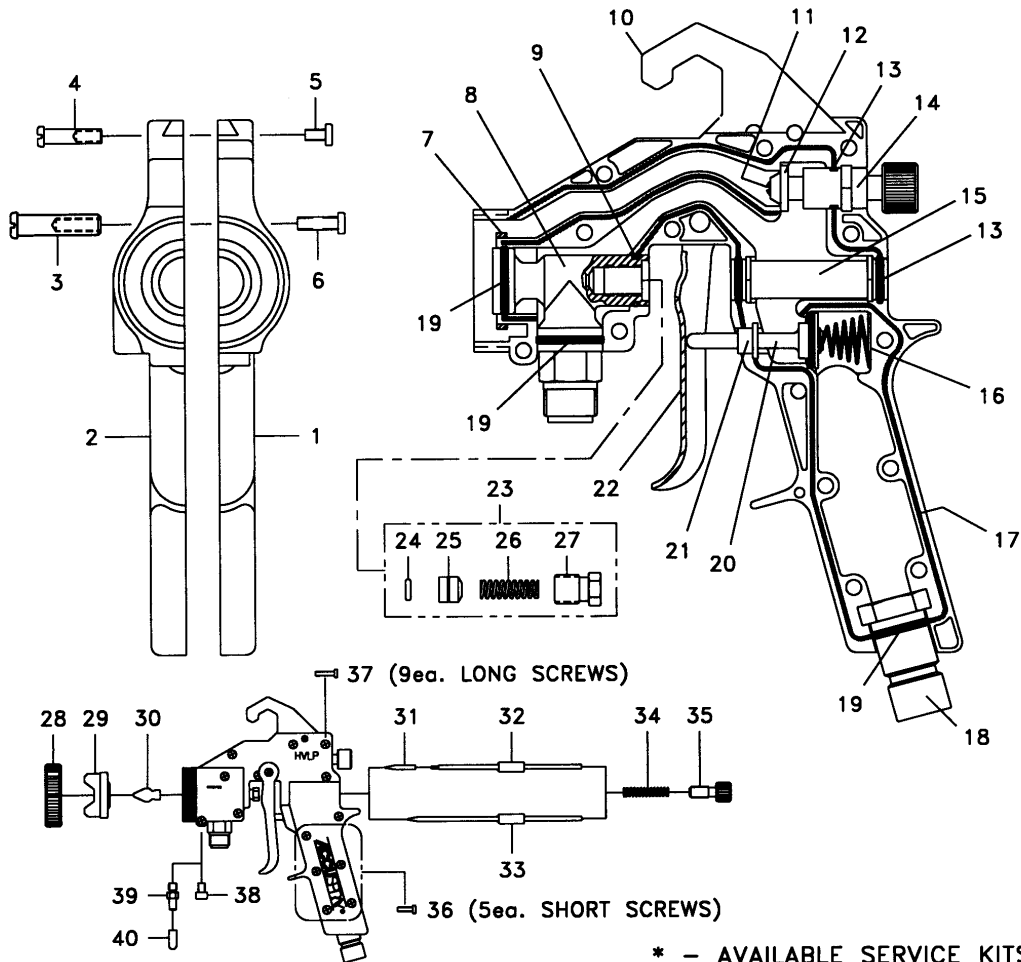

\* - AVAILABLE SERVICE KITS

ITEM	PART No.	DESCRIPTION
1	91-123-A	LEFT-HALF SPRAYGUN HANDLE
2	91-122	RIGHT-HALF SPRAYGUN HANDLE
3	91-014	TRIGGER PIVOT POST
4	91-141	HOOK POST
5	UH-869/4	HOOK POST SCREW
6	UH-769/4	TRIGGER PIVOT POST SCREW
7	91-276	CLOSURE RING
8	91-064	FLUID PASSAGE ASSEMBLY
9	UH-790/10	O-RING (PACK OF 10)
10	91-124	SPRAYGUN HOOK
11	UH-765/4	FAN VALVE ASSEMBLY SCREW
12	91-015	VALVE SEAL
13	UH-647/10	O-RING (PACK OF 10)
14	91-072	FAN VALVE ASSEMBLY
15	91-041	THREADED SLEEVE ASSEMBLY
16	91-019/5	TELESCOPIC SPRING
17	UH-753/2	SEAL
18	91-020	AIR INLET ASSEMBLY
19	UH-789/10	O-RING (PACK OF 10)
20	91-142	POPPET VALVE ASSEMBLY
21	91-021	FLANGED BUSHING
22	HP-405	TRIGGER

ITEM	PART No.	DESCRIPTION
23	91-200	SELF-ADJUSTING PACKING KIT
24	UH-1405/10	O-RING (PACK OF 10)
25	91-202/2	NEEDLE GUIDE (PACK OF 2)
26	91-199/3	COMPRESSION SPRING (PACK OF 3)
27	91-201	PACKING NUT
28	91-271	RETAINING RING
29	91-009-xxx	AIR CAP (DELTRIN)
29	91-071-xxx	AIR CAP (ALUMINUM)
30	91-008-xxx	FLUID NOZZLE
31	91-107-xxx/4	NEEDLE TIP (PACK OF 4)
32	91-078	NEEDLE SHAFT
33	91-006-xxx	FULL S.S. NEEDLE
34	LG-27/5	SPRING (PACK OF 5)
35	91-068	NEEDLE ADJUSTMENT SCREW
36	UH-800/10	1/2" (SHORT) SCREW (PACK OF 10)
37	UH-801/10	5/8" (LONG) SCREW (PACK OF 10)
38	UH-694/4	AIR PRESSURE PORT PLUG
39	LFG-465	AIR PRESSURE STEM
40	91-109/10	AIR PRESSURE STEM CAP
*	91-028	SPRAYGUN REBUILD KIT
*	91-049	O-RING REPLACEMENT KIT
*	91-152-A	HANDLE REPLACEMENT KIT

# Turbine Maintenance

## General Instructions

The turbine assembly should be cleaned and checked routinely. Care for your turbine unit as you would care any of your professional tools. The following steps should be taken to protect both yourself and the unit before proceeding.

- 1) Turn off the turbine unit and allow it to cool down before attempting to service it.
- 2) Unplug the turbine unit before attempting any service to it.

## Daily

Clean any material that may have accumulated on the turbine and wipe any materials from the hoses. Remove and clean the foam pre-filter by blowing it out with air or shaking it. **Note: Relief vent at the rear of the turbine must be kept clear at all times.**

## Weekly

Remove the two screws and the two washers that hold the atomizing air filter cover and the atomizing air filter. Remove and inspect the pleated paper filter by holding it up to a light. If you cannot see light through it, it must be replaced.

**Note: Keeping the turbine filters clean is extremely important. Dirty or clogged filters will dramatically reduce the life of the turbine. Order (#92-254) Turbine filter package.**

## After 1 year

Inspect the carbon motor brushes for wear. If the black portion of the brush is less than ½" long, it should be replaced.

To inspect or replace the carbon motor brushes, the motor assembly must be partially removed. Please see the motor assembly removal section before proceeding with this.

If unit is less than one year old, contact the factory before attempting this procedure.

## Motor Assembly Removal

To inspect the carbon motor brushes, remove the screws and washers that hold that hold the front cover and the back cover in place. Carefully remove the back cover. The front cover contains the rocker switch. You will need to disconnect the wires from the back of the switch before proceeding. Be certain to label the wire before disconnecting to assure proper reconnection. Remove the front cover.

The motor assembly can be easily removed from the outside frame by removing the four screws and washers. With these removed, the entire assembly may be pulled away from within the filter housing. With the fan guard cap clear of the filter housing, rotate the assembly 90 degrees, and set the turbine mounting base on the floor outside the frame.

The carbon brushes can now be inspected and replaced if necessary. First remove the fan guard cap. The fan guard cap is fastened to the carbon motor brushes by its own molded clips. Be careful, the clips are rigid, and excessive force may cause damage.

With the fan guard cap removed, remove the two screws that hold the "U" shaped bracket in place over the carbon motor brushes. Next, with the use of a small flat blade screwdriver, gently out the terminal from within the carbon motor brush. (Please refer to the illustration in the Parts Identification Section). This completes the inspection and removal

If it is completely necessary to remove the motor assembly because of damage or failure, two electrical connections must be addressed. The first is the ground connection at the turbine base. The second is the ground connection at the motor near the carbon motor brush. Each of these are easily disconnected by removing the screw. The motor assembly is now free and can be removed.

The motor assembly can be separated from the turbine mounting base by removing the three screws and the three washers. This will allow you to remove and replace the foam rubber gasket.

The air filter of the turbine motor can be removed from the outside of the turbine cabinet. The filter is made from foam and is compressible. Care will need to be taken to assure that during replacement, it is properly seated.

## Wiring Diagram

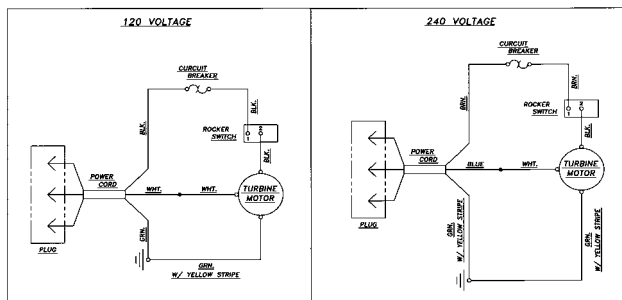

## 23 Series 3-Stage Turbine Parts Identification

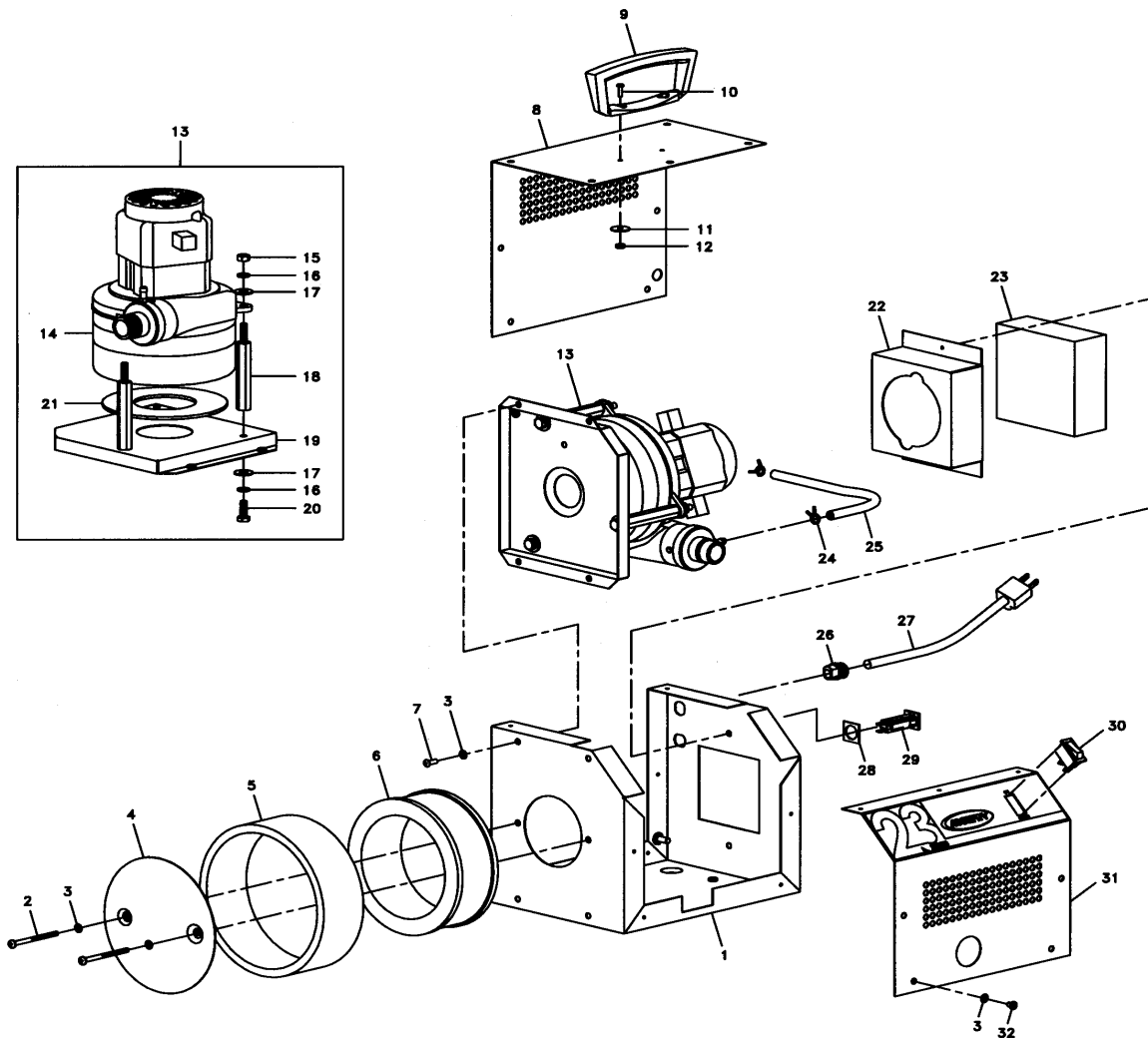

\* - Indicates 220 Voltage Part Numbers

<u>Item</u>	<u>P/N</u>	<u>Description</u>	<u>Item</u>	<u>P/N</u>	<u>Description</u>
1	92-175	OUTSIDE FRAME	17	UH-460	FLAT WASHER
2	UH-983	2-1/2" LONG MACH. SCREW	18	92-434	STAND-OFF
3	UH-727	STAR LOCK WASHER	19	92-433	MOUNTING BASE
4	92-008	FILTER COVER	20	UH-404	HEX HEAD BOLT
5	92-162	PRE-FILTER	21	92-161	TURB. MOUNTING GASKET
6	92-007	MEDIA FILTER	22	92-154	FILTER HOUSING
7	UH-776	1/2" LONG MACH. SCREW	23	92-156	AIR FILTER
8	92-179	COVER	24	UH-1135	HOSE CLAMP
9	92-144	HANDLE	25	RM-297/11	AIR RELIEF HOSE
10	UH-800	SCREW	26	BE-314	CORD STRAIN BUSHING
11	92-166	FLAT WASHER	27	92-006	ELECTRIC POWER CORD-110V
12	UH-911	HEX NUT	27*	(92-342)	(ELECTRIC POWER CORD-220V)
13	92-245	TURBINE ASS'Y W/BASE-110V	28	UH-444	CIRCUIT BREAKER GASKET
13*	(92-249)	(TURBINE ASS'Y W/BASE-220V)	29	EL-803	CIRCUIT BREAKER 12 AMP
14	92-077	TURBINE MOTOR ASS'Y-110V	29*	(EL-921)	(CIRCUIT BREAKER 7 AMP)
14*	(92-123)	(TURBINE MOTOR ASS'Y-220V)	30	92-210	ROCKER SWITCH
15	UH-422	HEX NUT	31	92-177	FRONT COVER
16	UH-458	SPLIT LOCK WASHER	32	UH-1092	3/8" I G S M SCREW

---

To order additional copies of this manual, call Accuspray  
Customer Service at 1-800-618-6860  
Or fax your request to (440) 498-9815  
Visit Us Online At: [www.accuspray.net](http://www.accuspray.net)  
Request Literature Number SM-23-0304

#### LIMITED WARRANTY

Accuspray warrants all equipment manufactured by and bearing its name to be free from defects in material and workmanship on the date of sale by an authorized Accuspray distributor to the original purchaser for use. Except as expressly stated in any Accuspray Special, Extended or Limited Warranty provided in writing by Accuspray, Accuspray shall for a period of twelve months from the date of sale, repair or replace any part of the equipment proven defective. This warranty applies only when the equipment is installed, operated and maintained in accordance with Accuspray's written recommendations.

This warranty does not cover, and Accuspray shall not be liable for, normal wear and tear components, any malfunction, damage, or wear caused by faulty installation, misapplication, abrasion, corrosion, inadequate or improper maintenance, negligence, accident, tampering, alteration or substitution of non-Accuspray component parts. Nor shall Accuspray be liable for malfunction, damage, or wear caused by the incompatibility with Accuspray equipment of structures, accessories, equipment or materials not supplied by Accuspray, or the improper design, manufacture, installation, operation or maintenance of structures, accessories, equipment or materials not supplied by Accuspray.

This warranty is conditional upon the prepaid return of the equipment claimed to be defective to an authorized Accuspray Service Center or to Accuspray, to verify the claimed defect. If the claimed defect is verified to be covered by this warranty, Accuspray will repair or replace free of charge any defective parts and the equipment will be returned to the original purchaser freight paid. If inspection of the equipment does not disclose a valid warranty claim, repairs, if any, will be made at a reasonable charge to the purchaser. These charges may include the cost of inspection, parts, labor, and return transportation.

**Disclaimer and Limitations.** The terms of this warranty constitute Accuspray's sole obligation and purchaser's sole and exclusive remedy and are in lieu of any other warranties (express or implied), including warranty of merchantability or warranty of fitness for a particular purpose, or any non-contractual liabilities, including product liabilities based on negligence or strict liability. Every form of liability for direct, special or consequential damages or loss is expressly excluded and denied. In no case shall Accuspray's liability exceed the amount of the purchase price. Any action for breach of warranty must be brought within two (2) years of date of sale.

**Equipment Not Covered by Accuspray Warranty.** Accuspray makes no warranty, and disclaims all implied warranties of merchantability and fitness for a particular purpose with respect to accessories, equipment, materials, or components sold but not manufactured by Accuspray. These items sold but not manufactured by Accuspray (such as electric motors, switches, hose, etc.), are subject to the warranty, if any, of their manufacturer. Accuspray will provide purchaser with reasonable assistance in making any claim for breach of these warranties.

Accuspray is a registered trademark of  
Accuspray Application Technologies, Inc.

All other products named in this publication are either trademarks or registered  
Trademarks of their respective owners.